

ELTL2-DI-INSTALLATION



RISK OF ELECTRICAL SHOCK. DISCONNECT POWER BEFORE INSTALLATION OR SERVICING.



TO BE INSTALLED BY A QUALIFIED ELECTRICIAN IN ACCORDANCE TO LOCAL & NATIONAL ELECTRIC CODES.



FAILURE TO COMPLY TO INSTRUCTIONS & FORMENTIONED WARNINGS COULD VOID PRODUCT WARRANTY



DO NOT CONSTRUCT ROW ON FLOOR & LIFT TO CEILING.



CEILING TO BE PROPERLY REINFORCED TO SUPPORT WEIGHT OF THE FIXTURE.



REFERENCE SHOP DRAWINGS FOR CRITICAL MOUNTING DIMENSIONS.

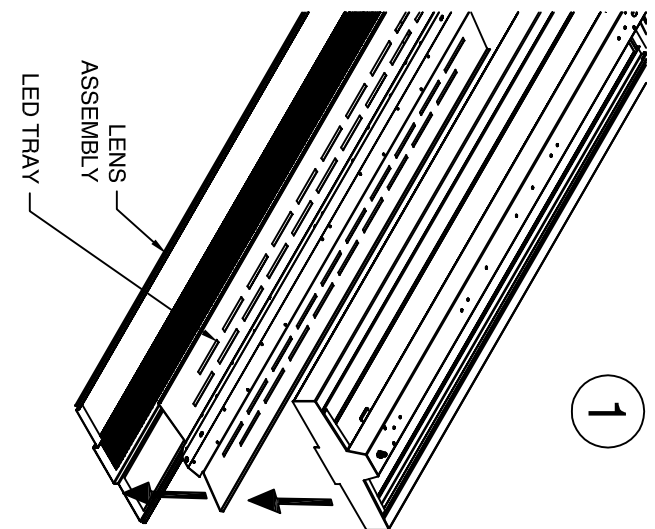

1. REMOVE LENS ASSEMBLY AND LED TRAY.

2. INSTALL ADJUSTABLE CABLE GRIPPER

3. HANG FIXTURE. INSTALL A/C CABLE IN MOUNTING LOCATIONS ACCORDING TO INSTRUCTIONS SUPPLIED WITH MOUNTING KIT. LIFT FIXTURE INTO POSITION AND FEED A/C CABLE THROUGH CABLE GRIPPER. TIGHTEN CABLE GRIPPER IN POSITION

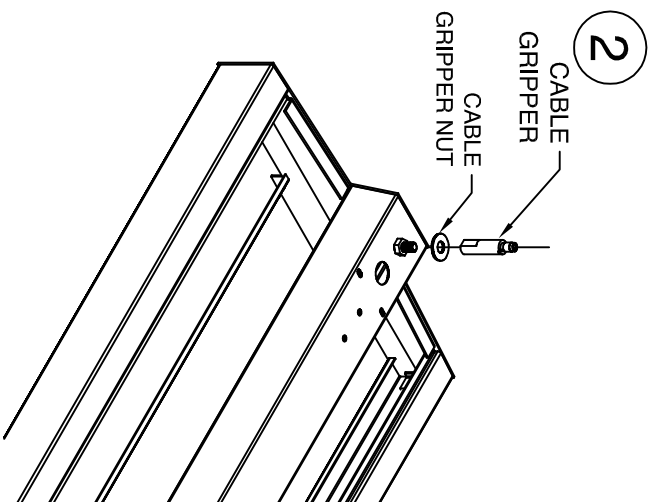

4.DETERMINE LOCATION OF POWER FEED HOLE. FEED POWER FEED CORD THROUGH HOLE IN FIXTURE. USE APPROPRIATE STRAIN RELIEF TO SECURE CORD IN FIXTURE AS REQUIRED BY LOCAL ELECTRICAL CODES. CONNECT POWER FEED CONDUCTORS TO APPROPRIATE WIRES OF FIXTURE. STANDARD WIRING DIAGRAM SHOWN, REFER TO JOB DRAWINGS FOR JOB SPECIFIC WIRING

5.REINSTALL LED TRAY AND LENS FOR ALL FIXTURES AFTER ALL WIRING CONNECTIONS ARE MADE. INSTALLATION IS COMPLETE

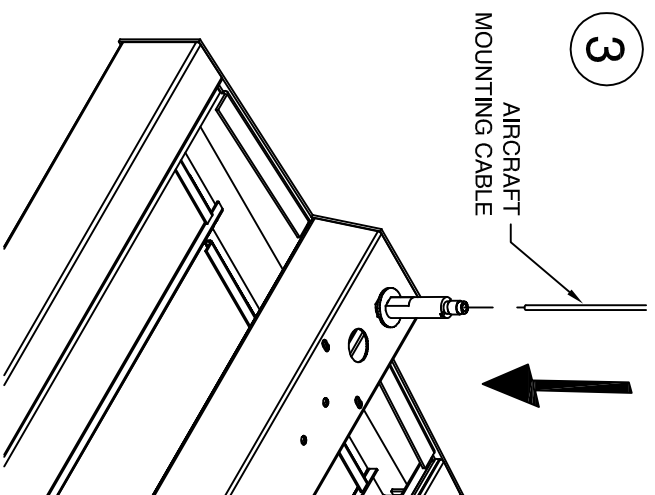

MUST BE INSTALLED BY A QUALIFIED ELECTRICIAN. DISCONNECT POWER DURING INSTALLATION/SERVICING. ROW CONFIGURATION IS JOB SPECIFIC. CONSULT SHOP DRAWINGS BEFORE CONSTRUCTING ROWS. STANDARD OPTIONS/SIZES SHOWN. OTHER OPTIONS AVAILABLE WITH SIMILAIR INSTALLATION. BE SURE TO UNDERSTAND ALL PROCEDURES PRIOR TO INSTALLATION. IMPORTANT: THE NATIONAL ELECTRIC CODE REQUIRES THAT ANY FIXTURE IN EXCESS OF 50 POUNDS MUST BE INDEPENDENTLY SUPPORTED OF THE OUTLET BOX. DAY-O-LITE IS NOT RESPONSIBLE FOR INADEQUATE REINFORCEMENT OF STRUCTURAL SUPPORT SYSTEMS. DAY-O-LITE RESERVES THE RIGHT TO MAKE ANY MECHANICAL OR MATERIAL CHANGES TO THE FIXTURES WHICH DO NOT AFFECT THE APPEARANCE OR PERFORMANCE. THIS PRINT IS THE PROPERTY OF DAY-O-LITE AND THE INFORMATION IT CONTAINS MAY NOT BE USED WITHOUT WRITTEN CONSENT OF DAY-O-LITE.

MODEL NO.: ELTL2-DI-AC----	ISSUED ON: 3/14/2024
CONTRACT INFORMATION: 128 Chestnut Street, Warwick, RI 02888 Tel. (401) 467-8232 Fax. (401) 941-2960 E-mail: sales@dayville.com WWW: http://www.dayville.com	PAGE: SHEET 1 OF 2
 Lighting Without Limits	

ELTL2-DI-INSTALLATION



RISK OF ELECTRICAL SHOCK. DISCONNECT POWER BEFORE INSTALLATION OR SERVICING.



TO BE INSTALLED BY A QUALIFIED ELECTRICIAN IN ACCORDANCE TO LOCAL & NATIONAL ELECTRIC CODES.



DO NOT CONNECT, MODIFY, SPLICE, OR TAP ANY WIRED CONNECTIONS UNDER POWER.

1. REMOVE LENS ASSEMBLY AND LED TRAY.
2. INSTALL ADJUSTABLE CABLE GRIPPER
3. HANG FIXTURE. INSTALL A/C CABLE IN MOUNTING LOCATIONS ACCORDING TO INSTRUCTIONS SUPPLIED WITH MOUNTING KIT. LIFT FIXTURE INTO POSITION AND FEED A/C CABLE THROUGH CABLE GRIPPER. TIGHTEN CABLE GRIPPER IN POSITION
4. DETERMINE LOCATION OF POWER FEED HOLE. FEED POWER FEED CORD THROUGH HOLE IN FIXTURE. USE APPROPRIATE STRAIN RELIEF TO SECURE CORD IN FIXTURE AS REQUIRED BY LOCAL ELECTRICAL CODES. CONNECT POWER FEED CONDUCTORS TO APPROPRIATE WIRES OF FIXTURE. STANDARD WIRING DIAGRAM SHOWN, REFER TO JOB DRAWINGS FOR JOB SPECIFIC WIRING
5. REINSTALL LED TRAY AND LENS FOR ALL FIXTURES AFTER ALL WIRING CONNECTIONS ARE MADE. INSTALLATION IS COMPLETE

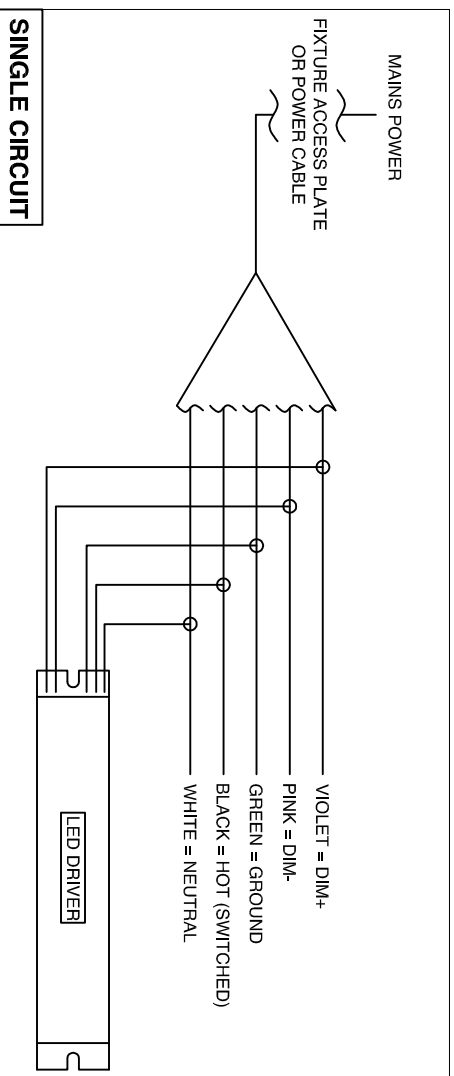
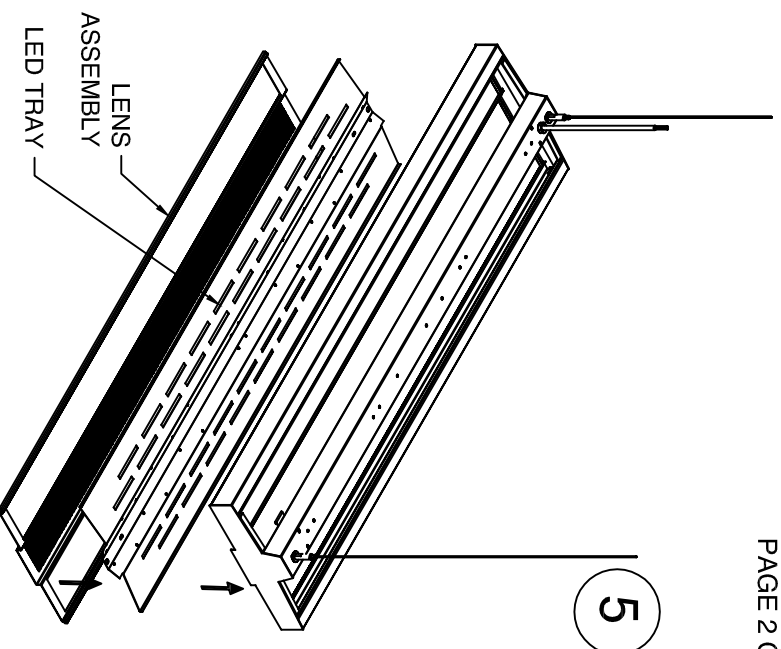
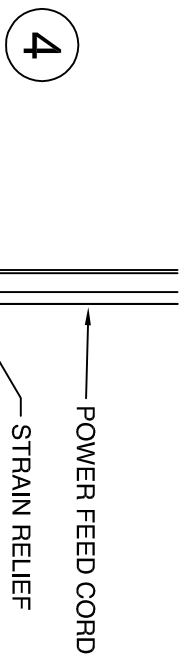

MUST BE INSTALLED BY A QUALIFIED ELECTRICIAN. DISCONNECT POWER DURING INSTALLATION/SERVICING. ROW CONFIGURATION IS JOB SPECIFIC. CONSULT SHOP DRAWINGS BEFORE CONSTRUCTING ROWS. STANDARD OPTIONS/SIZES SHOWN. OTHER OPTIONS AVAILABLE WITH SIMILAR INSTALLATION. BE SURE TO UNDERSTAND ALL PROCEDURES PRIOR TO INSTALLATION. IMPORTANT: THE NATIONAL ELECTRIC CODE REQUIRES THAT ANY FIXTURE IN EXCESS OF 50 POUNDS MUST BE INDEPENDENTLY SUPPORTED OF THE OUTLET BOX. DAY-O-LITE IS NOT RESPONSIBLE FOR INADEQUATE REINFORCEMENT OF STRUCTURAL SUPPORT SYSTEMS. DAY-O-LITE RESERVES THE RIGHT TO MAKE ANY MECHANICAL OR MATERIAL CHANGES TO THE FIXTURES WHICH DO NOT AFFECT THE APPEARANCE OR PERFORMANCE. THIS PRINT IS THE PROPERTY OF DAY-O-LITE AND THE INFORMATION IT CONTAINS MAY NOT BE USED WITHOUT WRITTEN CONSENT OF DAY-O-LITE.

MODEL NO.: ELTL2-DI-AC-....	PAGE: SHEET 2 OF 2	PART NUMBER: 970047A0
CONTRACT INFORMATION: 126 Chestnut Street, Warwick, RI 02888 Tel. (401) 467-8232 Fax. (401) 941-2960 E-mail: sales@dayolite.com WWW: http://www.dayolite.com	ISSUED ON: 3/14/2024	
		DAY-O-LITE Lighting Without Limits