





EQL SURFACE MOUNT INSTALLATION INSTRUCTIONS

 TO BE INSTALLED BY A QUALIFIED ELECTRICIAN IN ACCORDANCE TO LOCAL & NATIONAL ELECTRIC CODES.

 LEDS ARE EASILY DAMAGED, AVOID CONTACT WHEN INSTALLING AND SERVICING.

 DAY-O-LITE ASSUMES NO RESPONSIBILITIES FOR CLAIMS FOUNDED FROM IMPROPER INSTALLATION OR HANDLING.

 RISK OF ELECTRICAL SHOCK. DISCONNECT POWER BEFORE INSTALLATION OR SERVICING.

 RISK OF BURN. DO NOT TOUCH LED DIODE OR DRIVER WHEN SERVICING. ALLOW TO COOL BEFORE HANDLING.

 CEILING TO BE PROPERLY REINFORCED TO SUPPORT WEIGHT OF THE FIXTURE.

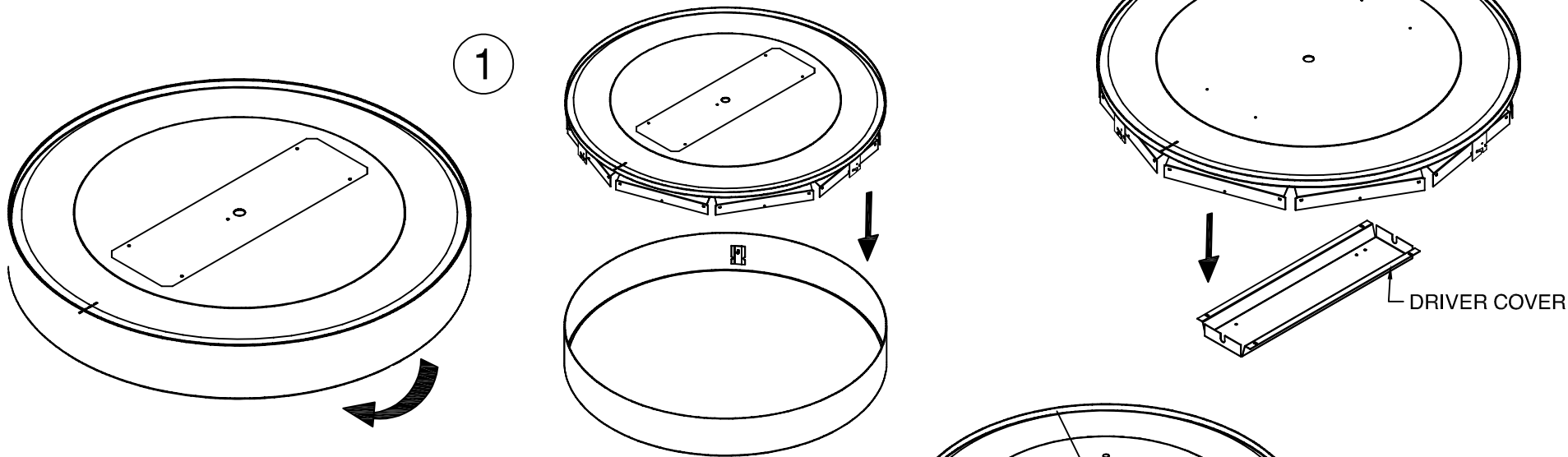

1. REMOVE LENS RING FROM FIXTURE. TWIST LENS RING COUNTERCLOCKWISE AND PULL AWAY FROM FIXTURE. **USE CAUTION TO NOT DROP LENS. LENS RING IS EASILY DENTED, HANDLE WITH CARE!**

2. REMOVE DRIVER COVER FROM FIXTURE

3. PUSH SUPPLY WIRE (BY OTHERS) THROUGH HOLE IN CENTER OF FIXTURE. BE SURE TO ALLOW ENOUGH WIRE TO MAKE CONNECTIONS. SECURE FIXTURE TO CEILING USING APPROPRIATE HARDWARE (BY OTHERS)

4. CONNECT SUPPLY WIRES AND FIXTURE WIRES USING APPROPRIATE CONNECTOR PER LOCAL ELECTRICAL CODES. STANDARD WIRING DIAGRAM SHOWN, REFER TO JOB DRAWINGS FOR JOB SPECIFIC WIRING

5. RE-INSTALL DRIVER COVER

6. RE-INSTALL LENS BY LIFTING ONTO FIXTURE AND TURNING COUNTER-CLOCKWISE UNTIL SECURE

7. INSTALLATION IS COMPLETE

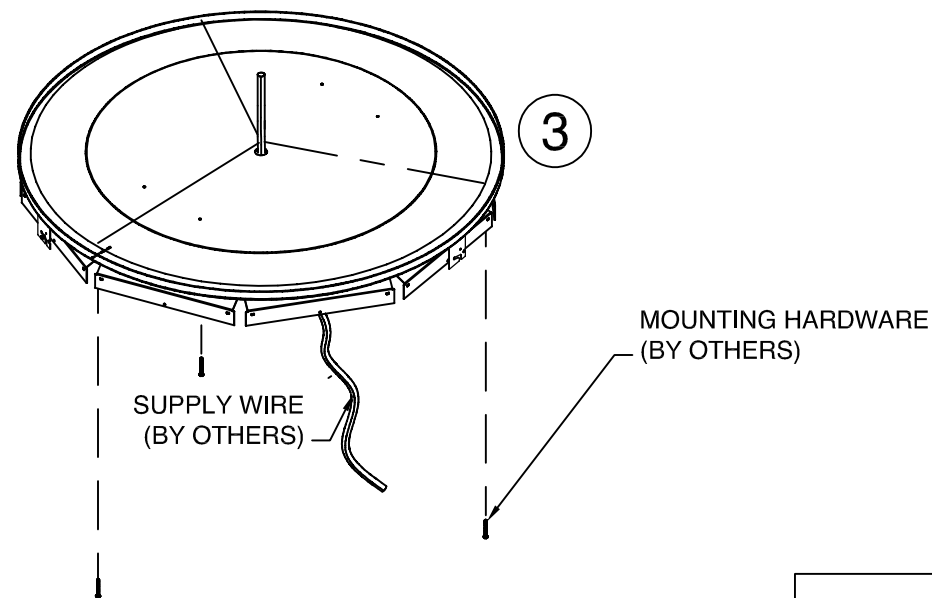

MUST BE INSTALLED BY A QUALIFIED ELECTRICIAN. DISCONNECT POWER DURING INSTALLATION/SERVICING. ROW CONFIGURATION IS JOB SPECIFIC, CONSULT SHOP DRAWINGS BEFORE CONSTRUCTING ROWS. STANDARD OPTIONS/SIZES SHOWN, OTHER OPTIONS AVAILABLE WITH SIMILAIR INSTALLATION. BE SURE TO UNDERSTAND ALL PROCEDURES PRIOR TO INSTALLATION. IMPORTANT: THE NATIONAL ELECTRIC CODE REQUIRES THAT ANY FIXTURE IN EXCESS OF 50 POUNDS MUST BE INDEPENDENTLY SUPPORTED OF THE OUTLET BOX. DAY-O-LITE IS NOT RESPONSIBLE FOR INADEQUATE REINFORCEMENT OF STRUCTURAL SUPPORT SYSTEMS. DAY-O-LITE RESERVES THE RIGHT TO MAKE ANY MECHANICAL OR MATERIAL CHANGES TO THE FIXTURES WHICH DO NOT AFFECT THE APPEARANCE OR PERFORMANCE. THIS PRINT IS THE PROPERTY OF DAY-O-LITE AND THE INFORMATION IT CONTAINS MAY NOT BE USED WITHOUT WRITTEN CONSENT OF DAY-O-LITE.

MODEL NO.:
EQL-PND----

CONTACT INFORMATION:
126 Chestnut Street, Warwick, RI 02888
Tel. (401) 467-8232 | Fax. (401) 941-2960
E-mail: sales@dayolite.com
WWW: http://www.dayolite.com

PAGE:
SHEET 1 OF 2

ISSUED ON:
9/9/2020



970109A0

EQL SURFACE MOUNT INSTALLATION INSTRUCTIONS

 RISK OF ELECTRICAL SHOCK. DISCONNECT POWER BEFORE INSTALLATION OR SERVICING.

 RISK OF BURN. DO NOT TOUCH LED DIODE OR DRIVER WHEN SERVICING. ALLOW TO COOL BEFORE HANDLING.

 CEILING TO BE PROPERLY REINFORCED TO SUPPORT WEIGHT OF THE FIXTURE.

 DAY-O-LITE ASSUMES NO RESPONSIBILITIES FOR CLAIMS FOUNDED FROM IMPROPER INSTALLATION OR HANDLING.

4

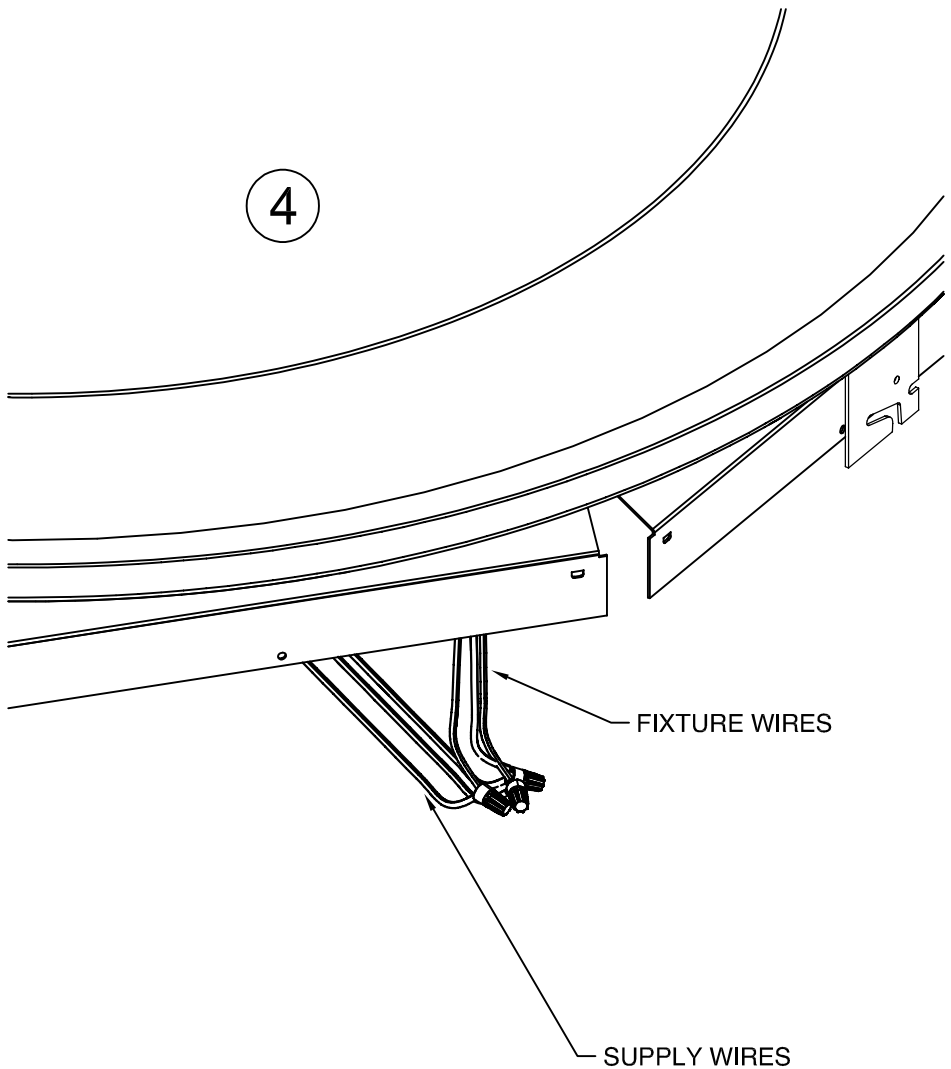

 TO BE INSTALLED BY A QUALIFIED ELECTRICIAN IN ACCORDANCE TO LOCAL & NATIONAL ELECTRIC CODES.

 LEDS ARE EASILY DAMAGED, AVOID CONTACT WHEN INSTALLING AND SERVICING.

 FAILURE TO COMPLY TO INSTRUCTIONS & FORMENTIONED WARNINGS COULD VOID PRODUCT WARRANTY

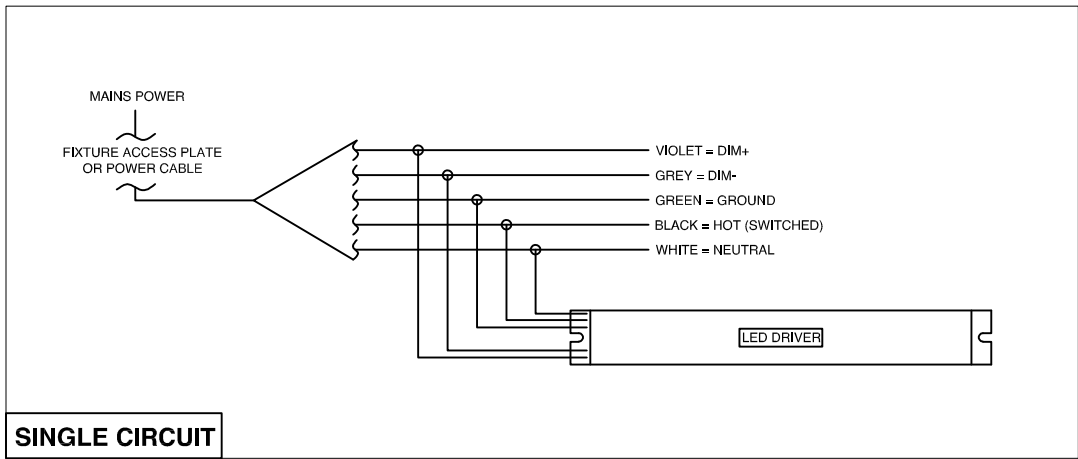

MUST BE INSTALLED BY A QUALIFIED ELECTRICIAN. DISCONNECT POWER DURING INSTALLATION/SERVICING. ROW CONFIGURATION IS JOB SPECIFIC, CONSULT SHOP DRAWINGS BEFORE CONSTRUCTING ROWS. STANDARD OPTIONS/SIZES SHOWN, OTHER OPTIONS AVAILABLE WITH SIMILAIR INSTALLATION. BE SURE TO UNDERSTAND ALL PROCEDURES PRIOR TO INSTALLATION. IMPORTANT: THE NATIONAL ELECTRIC CODE REQUIRES THAT ANY FIXTURE IN EXCESS OF 50 POUNDS MUST BE INDEPENDENTLY SUPPORTED OF THE OUTLET BOX. DAY-O-LITE IS NOT RESPONSIBLE FOR INADEQUATE REINFORCEMENT OF STRUCTURAL SUPPORT SYSTEMS. DAY-O-LITE RESERVES THE RIGHT TO MAKE ANY MECHANICAL OR MATERIAL CHANGES TO THE FIXTURES WHICH DO NOT AFFECT THE APPEARANCE OR PERFORMANCE. THIS PRINT IS THE PROPERTY OF DAY-O-LITE AND THE INFORMATION IT CONTAINS MAY NOT BE USED WITHOUT WRITTEN CONSENT OF DAY-O-LITE.

MODEL NO.: EQL-PND----		PAGE: SHEET 2 OF 2	970109A0 ISSUED ON: 9/9/2020
CONTACT INFORMATION: 126 Chestnut Street, Warwick, RI 02888 Tel. (401) 467-8232 Fax. (401) 941-2960 E-mail: sales@dayolite.com WWW: http://www.dayolite.com		 <p>DAY-O-LITE Lighting Without Limits</p>	