



Trilogy Series | TRIL-14-DI Acoustic

Date	Notes
Project	
Type	Qty



20 unique colors & 4 wood grain finishes.

Features

- Combines noise control and illumination.
 - Extruded aluminum housing w/welded end-plates.
 - LED optimized optics for smooth, efficient illumination.
 - Programmable driver for custom lumen packages.
 - 0-10V dimming to 1% standard or Dim-to-Off.
 - DMX, Lutron and DALI protocols also available.
 - Sensor Ready for wireless Smart Lighting Solutions.
 - 80/90CRI, Tunable White, RGBW & RGBWW.
 - Bios SkyBlue™ circadian solutions available.
- Declare** Red List Approved.

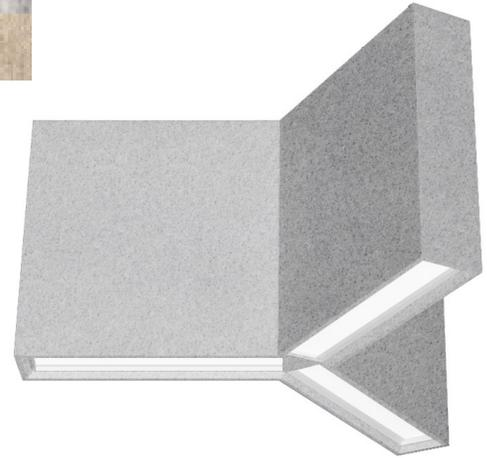
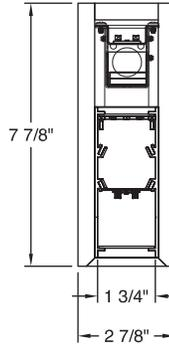

Ordering Guide



MODEL	OPTICS	CCT ¹	LUMENS ²	LENGTH	MOUNTING ³	FINISH	OPTIONS
TRIL-14-DI							
TRIL-14-DI Direct/Indirect Acoustic	<p>DIRECT LENS</p> <p>SI = Satin Ice Acrylic (lay-in)</p> <p>INDIRECT LENS</p> <p>CA = Clear Acrylic (Standard lay-on)</p> <p>SI = Satin Ice Acrylic (lay-in)</p>	<p>27 = 2700K 80CRI 30 = 3000K 80CRI 35 = 3500K 80CRI 40 = 4000K 80CRI 50 = 5000K 80CRI</p> <p>BIOS SkyBlue Spectrally optimized circadian solutions.</p> <p>TUNABLE WHITE (2700K-6500K) 2DIM10 = for 0-10V 2DMX = for DMX 2ESN = for Philips 2CAS = for Casambi 2LUT = for Lutron</p> <p>DIM-TO-WARM (2700K-6500K) DTW = Dim-to-Warm</p> <p>RGB + WHITE RGB = RGB RGBW = RGBW RGBWW = RGBWW</p>	<p>2' LUMENS LO = 2280 (23W, 99LPW) SO = 3099 31W, 99LPW)</p> <p>HO = 3761 (39W, 96LPW)</p> <p>4' LUMENS LO = 5798 (55W, 106LPW) SO = 7795 (73W, 106LPW)</p> <p>HO = 9531 (91W, 105LPW)</p> <p>6' LUMENS LO = 9276 (86W, 108LPW) SO = 12,402 (115W, 108LPW)</p> <p>HO = 15,338 (144W, 107LPW)</p> <p>CUSTOM Specify < HO.</p>	<p>2 = 2' Dia. 4 = 4' Dia. 6 = 6' Dia. See page 3/4.</p>	<p>STANDARD AC = Aircraft Cable (3)</p> <p>ACM = Aircraft Mono-Point (3-into-1)</p> <p>PD = Pendant Stem (3)</p>	<p>FIXTURE HOUSING W = White CC = Custom Color</p> <p>ACOUSTIC SOLUTIONS See page 3 for Acoustic color options, ordering codes and technical information.</p>	<p>DIMMING DRIVERS DIM10 = 0-10V (1%) Standard DTO = 0-10V (Dim-to-Off) DIMST = 0-10V Step Dimming DIMSR = DALI Sensor Ready (5.0%) DALI = DALI (5.0%) DMX = DMX</p> <p>LUTRON™ DIMMING DRIVERS LDE1 = Hi-Lume 1% EcoSystem LD2 = Digital 1% (DALI-2) L3DA3W = Hi-Lume 1% 3-Wire</p> <p>SENSORS & CONTROLS⁴ AVO = Avi-On Sensor AWNS = Lutron Athena Sensor ESN = EasySense Sensor CAS = Casambi Wireless Control</p> <p>EMERGENCY⁵ EMC = Emergency Circuit GTD = Generator Transfer Device EPC4 = 4W Emergency Battery EPC6 = 6.5W Emergency Battery EPC10 = 10W Emergency Battery EPC12 = 12W Emergency Battery</p> <p>WIRING & OTHER FWH = Flexible Wiring Harness DWH = DMX Wiring Harness</p>

¹All LED, BIOS, Tunable White, DTW, and RGB/W options and Ordering Codes page 2.

²Lumens at 80CRI, 4000K, SI lens. Photometry page 4.

³See page 4 for mounting option details.

⁴All Sensor & Control options page 2.

⁵EPC6 is standard unless otherwise specified. EPC not for DMX drivers.

BAA letter of compliance available at www.dayolite.com.

LED, BIOS, Sensor & Control Ordering Codes

LED

Static White

30 = 3000K 80 CRI
 35 = 3500K 80 CRI
 40 = 4000K 80 CRI
 50 = 5000K 80 CRI

927 = 2700K 90 CRI
 930 = 3000K 90 CRI
 935 = 3500K 90 CRI
 940 = 4000K 90 CRI

Tunable White¹
 (2700K-6500K)

2DIM10 = 0-10V 80 CRI
 2DMX = DMX 80 CRI
 2CAS = Casambi Wireless 80 CRI
 2ESN = Philips EasySense 80 CRI
 2LUT = Lutron (LD2) 80 CRI

92DIM10 = 0-10V 90 CRI
 92DMX = DMX 90 CRI
 92CAS = Casambi Wireless 90 CRI
 92ESN = Philips EasySense 90 CRI
 92LUT = Lutron (LD2) 90 CRI

Dim-to-Warm²

DTW = 6500K-2700K 80 CRI
 9DTW = 5000K-3000K 90 CRI

RGB/W³

(80 CRI, Consult factory for 90 CRI)

RGB = RGB only
 RGB27 = RGB w/2700K
 RGB30 = RGB w/3000K
 RGB35 = RGB w/3500K
 RGB40 = RGB w/4000K
 RGB50 = RGB w/5000K
 RGBWW = RGB w/2700K-6500K

Single Color⁴

RED = Red
 BLU = Blue
 GRN = Green
 AMB = Amber

BIOS SkyBlue



BIOS SkyBlue biological technology brings the benefits of blue skies inside. BIOS SkyBlue is the only spectrally optimized circadian solution to pinpoint the region that drives wellness benefits including: increased alertness, enhanced productivity, better mood, and better sleep. More information may be found at www.bioslighting.com or by contacting Day-O-Lite directly. All options for 0-10V control.

BIOS Biological Static

For daytime applications. BIOS Static Biological LED features key BIOS SkyBlue (490nm) for maximum daytime circadian impact.

B30 = 3000K
 B35 = 3500K
 B40 = 4000K

BIOS Biological Dynamic White

Designed to transition from daytime to evening in a dim-to-warm protocol. The daytime CCT includes full BIOS SkyBlue (490nm) for maximum daytime circadian impact, while the evening spectrum removes BIOS SkyBlue for a minimal circadian stimulus after hours.

B30D = 3000K-2700K
 B35D = 3500K-3000K
 B40D = 4000K-3500K

BIOS Biological Tunable White

Designed to transition from daytime to evening in a tunable white protocol. The daytime CCT includes full BIOS SkyBlue (490nm) for maximum daytime circadian impact, while the evening spectrum removes BIOS SkyBlue for a minimal circadian stimulus after hours.

B30T = 3000K-2700K
 B35T = 3500K-2700K
 B40T = 4000K-2700K

Sensors & Controls

Sensors

AVO = Avi-On Occ/Day
 AVM = Avi-On Occ (Microwave)
 BNV = BubblyNet Occ/Day
 ENC = Encelium Occ/Day
 ENL = EnLighted Occ/Day/Temp
 LEG = Legrand Occ/Day
 ANW = Lutron Athena Occ/Day
 VIVE = Lutron Vive Occ/Day
 NLT = Acuity nLight Occ/Day
 NXC = Current NX Occ/Day
 ESN = Philips EasySense Occ/Day
 WVW = Cooper WaveLinx Occ/Day

Wireless Control

CAS = Casambi

Sensors and control options to be commissioned wirelessly in the field by qualified controls personnel with applicable apps (by others).

Other Options

Other sensor and wireless control options are available. Contact factory for details.

¹Tunable white may be controlled by a number of dimming protocols as shown.

²Dim-to-Warm mimics incandescent dimming by warming the CCT from 6500K to 2700K as light levels are dimmed.

³All RGB, RGBW and RGBWW options for DMX control (by others).

⁴Single colors are constant voltage LEDs. Dimming requires ELV controller (by others).

Day-O-Lite's acoustic options integrate energy efficient architectural lighting with advanced sound absorbing technology in a sustainable, eco-friendly solution. Functional, attractive and easy to install, Day-O-Lite's acoustic solutions are ideal for use in educational, office, commercial, theatre and lobby applications.



HOW TO SPECIFY

- 1) Select color code from color swatches above.
- 2) Select height of acoustic panel - 8", 12" or 16".
- 3) Combine color and height to make complete code. Example: SK-12 = Sky, 12" high, FO-8 = Fossil, 8" high.
- 4) Enter completed code in Options section of Ordering Guide on page 1 of this Specification Sheet.

SPECIFICATIONS

- 100% Recyclable Polyester Material
- 1.6 Noise Reduction Coefficient (NRC)
- Class A Fire Rating
- Moisture and Mold Resistant
- UV Fade Resistant
- Stain repellent available



NON-ILLUMINATED BAFFLES

Non-Illuminated baffles matching the color and size of specified fixtures may also be ordered. These may be used as "fillers" between fixtures for added sound suppression, or alone as decorative elements. Specify as follows: TRIL-14-NIB (non-illuminated baffle)-XX (color)-YY (panel height). Example: TRIL-14-NIB-SL-16 = Trilogy 14 size, non-illuminated baffle, Slate color, 16" high panel. Day-O-Lite non-illuminated baffles are supplied with the same aircraft cable suspension as our acoustic luminaires and feature a closed bottom with a bevel detail to match fixtures.

ADDITIONAL INFORMATION

Smoke, Pewter and Slate are standard colors; consult factory for lead-times on other colors. Acoustic panels ship affixed to luminaires and are held in place by stop-blocks and double-sided tape to prevent bowing. On site removal may result in damage and void warranty. Fixtures must be stored and installed in an interior dry location at a minimum of 52F.

A NOTE ON SOUND ABSORPTION

Per ASTM C423 there is no standard way to calculate sound absorption coefficients of non-standard shapes, sizes or spacing of material. Day-O-Lite's acoustic fixtures are tested using ASTM E795-16 Standard "Practices for Mounting Test Specimens During Sound Absorption Test", resulting in a noise reduction coefficient (NRC) unique to the test setup. When comparing sound suppressing materials those with a higher NRC will absorb more sound than those with a lower NRC, assuming the same test method is employed.

Additionally, more sound absorbing material in a space will result in greater sound suppression than less. Acoustic fixtures with 16" tall panels will be more effective at sound absorption than those with 8" or 12" high panels.

The full Acoustic Test Report, Certified Letter of Apparent NRC and Storage, Cleaning and Care information is available at www.dayolite.com.

CUSTOM ACOUSTICS

Acoustic Solutions may also be ordered in custom panel heights and with other custom modifications. Please contact Day-O-Lite directly to discuss your custom acoustic solutions today.

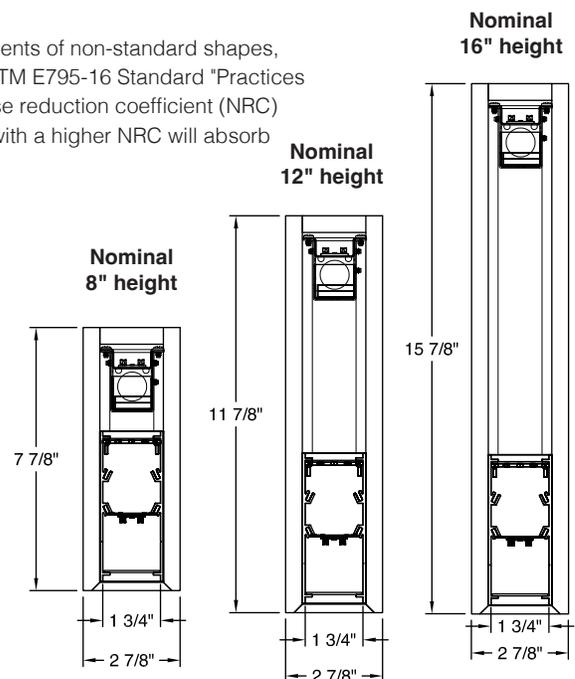

Sizes & Suspension Locations

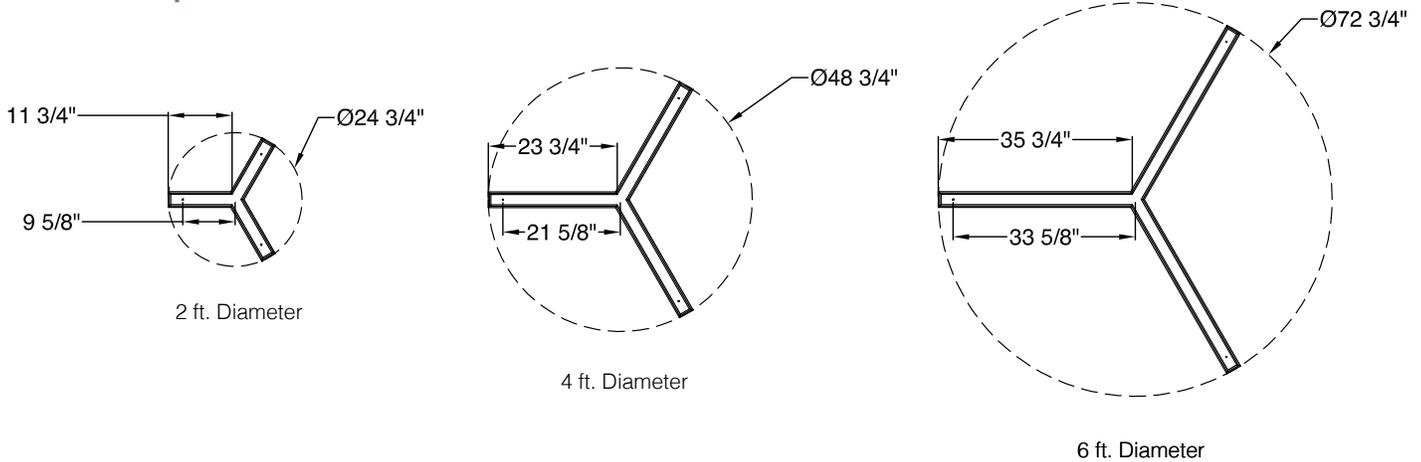

Standard Suspensions

Standard suspension options include adjustable self-locking aircraft cables (AC), a 3-into-1 monopoint (ACM).

AC assembly is 48" x 1/16" with a 5" feed canopy and 2" suspension canopies. 60" 18 gauge power and 22 gauge dimming control SJT feed.

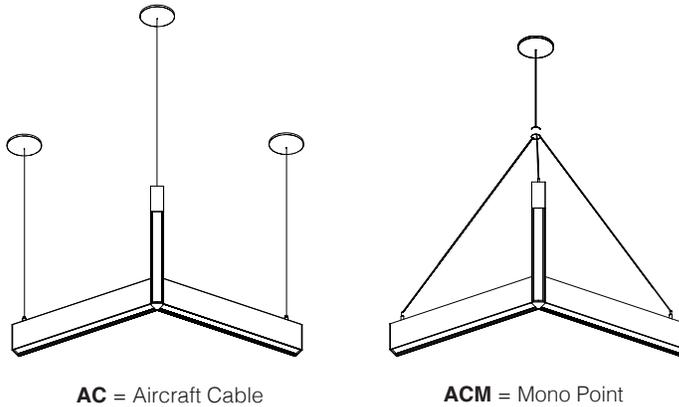

Photometry

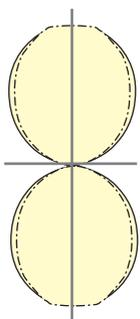

TRIL-14-DI-SI-40-2	TRIL-14-DI-SI-40-4	TRIL-14-DI-SI-40-6
LO 4000K CCT WATTS: 23 LUMENS: 2280 LPW: 99 Distribution: 53% Direct 47% Indirect	LO 4000K CCT WATTS: 55 LUMENS: 5798 LPW: 106 Distribution: 53% Direct 47% Indirect	LO 4000K CCT WATTS: 86 LUMENS: 9276 LPW: 108 Distribution: 53% Direct 47% Indirect
SO 4000K CCT WATTS: 31 LUMENS: 3099 LPW: 99 Distribution: 53% Direct 47% Indirect	SO 4000K CCT WATTS: 73 LUMENS: 7795 LPW: 106 Distribution: 53% Direct 47% Indirect	SO 4000K CCT WATTS: 115 LUMENS: 12,402 LPW: 108 Distribution: 53% Direct 47% Indirect
HO 4000K CCT WATTS: 39 LUMENS: 3761 LPW: 96 Distribution: 53% Direct 47% Indirect	HO 4000K CCT WATTS: 91 LUMENS: 9531 LPW: 105 Distribution: 53% Direct 47% Indirect	HO 4000K CCT WATTS: 144 LUMENS: 15,338 LPW: 107 Distribution: 53% Direct 47% Indirect

40000K @ 80CRI, SI lens.

Use the following multipliers for other CCTs: 2700K x 0.94, 3000K x 0.96, 3500K x 0.98, 5000K x 1.02. IES files @ www.dayolite.com

Specifications

ACOUSTIC PANELS: 1/2" thick, 100% recyclable polyester material, Class A fire rating, moisture, mold and UV fade resistant.

CONSTRUCTION: Extruded aluminum housing. 20 gauge cold rolled steel internal components.

REFLECTOR: Die-formed steel finished in highly reflective baked white enamel with pre-finished reflective LED tray.

OPTICS: LED optimized, shatter resistant Satin Ice acrylic regressed lens.

LED: Static white LED modules in 27/30/35/40 & 50K CCT, 80/90CRI. Lumen maintenance minimum $L_{70} = 50,000$ hours. 3 SDCM color consistency. BIOS SkyBlue, RGB, RGBW, RGBWW. Tunable White and Dim-to-Warm options available.

DRIVER: Standard driver is Class 2 AOC 0-10V to 1%, Dim-to-Off available. 120/277V input, PF > 90%, THD < 20 @ 120V. Additional dimming protocols available. All drivers prewired from factory for connection to control system (by others), field replaceable.

MOUNTING: Standard options include adjustable self-locking aircraft cables, and a 3-into-1 aircraft cable monopoint. AC assembly is 48" x 1/16" with a 5" feed canopy and 2" suspension canopies. 18 gauge power and 22 gauge dimming control SJT feed.

FINISH: Housing and components finished in baked white enamel. Canopies and pendant stems are white enamel unless otherwise specified.

CERTIFICATION: Luminaires are cETLus listed conforming to UL STD. 1598 and certified to CSA STD C22.2 NO. 250.0. Suitable for dry & damp locations. Union Made in the United States of America. I.B.E.W., BAA compliant, Declare Red List Approved.

LEGAL: Day-O-Lite, a division of SCW Corporation. All rights reserved. The Day-O-Lite logo is a registered trademark of SCW Corporation. Day-O-Lite reserves the right to change specifications without notice for product improvement.